

Electro Standards Laboratories Wave Energy Buoy Systems

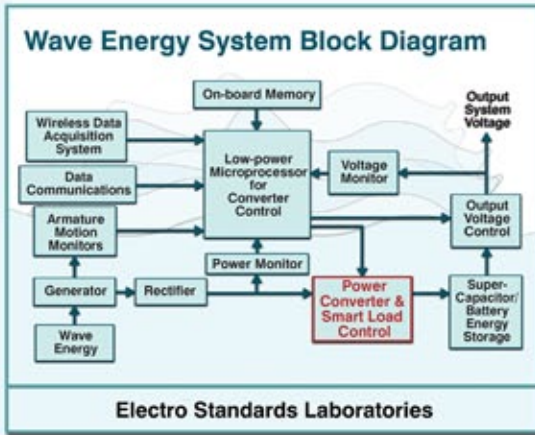

This small buoy sensor system generates and accumulates energy that can be used to indefinitely power remote buoys equipped with sensor arrays as well as electronics for processing and communications. This power source can be used to minimize the size of batteries, or eliminate the need for batteries if supercapacitors are used. The buoy system design is customized and scalable (1-250 W) and can be for moored or drifting applications.

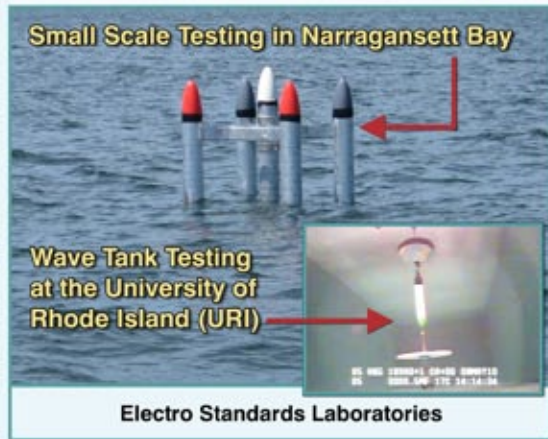

Electro Standards Laboratories
36 Western Industrial Drive
Cranston, RI 02921



Electro Standards Laboratories
ADVANCED SYSTEMS DESIGN & SERVICES

Ocean Wave Energy Harvesting System Designed for Sensor Buoys

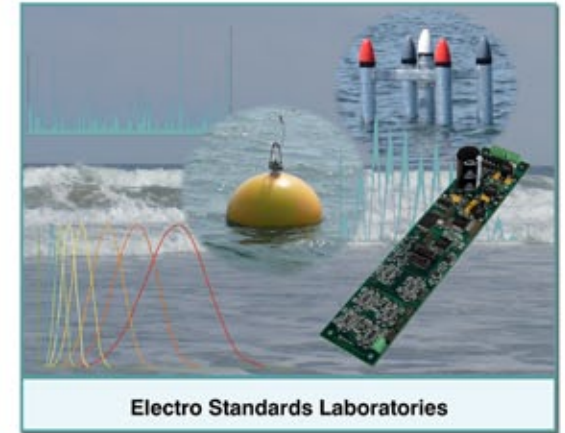

Targeted Applications:

- ◆ Recharging Station for UUV (unmanned underwater glider)
- ◆ Replacement for Solar Power
- ◆ Augmentation of Solar Power
- ◆ Elimination of Batteries
- ◆ Sonar Listening Station
- ◆ Weather Monitoring Buoys
- ◆ Wave Monitoring Buoys
- ◆ Tsunami Warning Stations
- ◆ Port Monitoring Buoys

Dr. Raymond B. Sepe, Jr.
Vice President Research & Development
Electro Standards Laboratories
36 Western Industrial Drive
Cranston, RI, 02921
Tel: 401-943-1164
rsepe@ElectroStandards.com

www.ElectroStandards.com

Electro Standards Laboratories & the University of Rhode Island Collaborate on Wave Energy

Direct Drive System



Resonant Drive System

ESL is addressing the need for extended operation of autonomous sensor buoys or other remote ocean platforms. Many existing remote ocean-based platforms currently are powered by batteries or by batteries in combination with solar power. As a solution to augment or replace any of these electrical-power-providing systems deployed in the ocean environment, power harvesting from ambient ocean wave energy becomes a natural and viable option.

Collaboration with the University of Rhode Island (URI) has produced two concept designs to address these needs. One concept is a **direct drive system** which provides power from the differential motion between the buoy float and a submerged resistant plate. The other concept is a **resonant drive system** which amplifies the generator's armature motion at the peak period of the sea state.

Scale model testing has been performed in the URI Department of Ocean Engineering wave tank as well as at the mouth of Narragansett Bay. ESL model simulations have shown good agreement with scale model tests.

Direct Drive System for Ocean Wave Energy Harvesting

Power Plot Example: (Sea State 1)

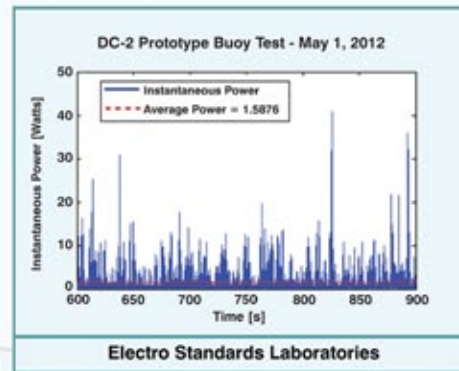

This technology employs small electric generators that are **directly driven** via a surface buoy's wave-induced heave motion. This configuration provides reliable operation without the need for additional gearing and has the ability to harness electrical power in the 1 to 10 Watt range in small sea states. (WMO Sea State 1: Calm)

Buoy response is designed to match a wide range of expected ocean wave spectra based on the deployment location. Direct Drive of the system with wave motion results in broad band response with high efficiency. Other benefits of this system include low acoustic noise and stealthy operation.

Wide Band Response to Wave Period

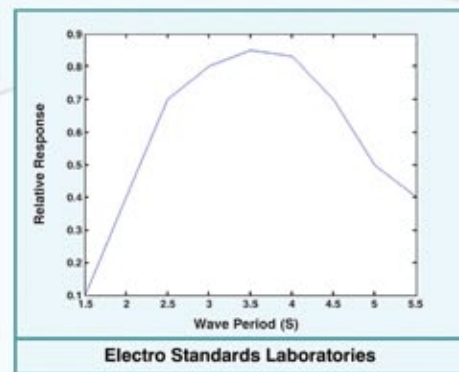

Resonant Drive System for Ocean Wave Energy Harvesting

Power Plot Example: (Sea State 1)

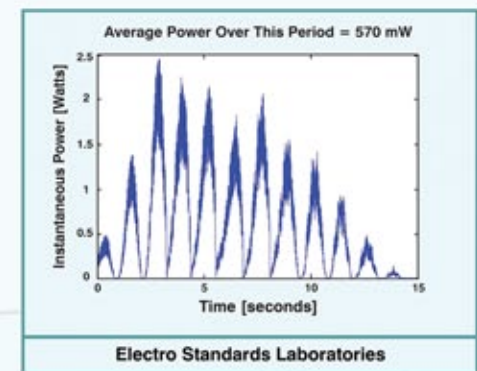

This technology employs small electric generators that are **resonantly driven** via a surface buoy's wave-induced heave motion. This configuration provides reliable operation without the need for additional gearing and has the ability to harness electrical power in the 1 to 10 Watt range in small sea states. (WMO Sea State 1: Calm)

Buoy resonant response is designed to match the expected ocean wave spectrum based on the deployment location. The benefits of the resonant system include enhanced functionality higher performance and continuous operation. The buoy is completely sealed with no external moving parts.

Example Buoy Response

