

PathWay® Model 7426 RJ45 Cat5 A/B/C/D Switch, with Telnet and GUI Remote Control

▪ Switch ANY RJ45 Cat5 (2 Pair) Interface

INTRODUCTION

The PathWay® Model 7426 RJ45 Cat5 A/B/C/D Switch with Telnet and GUI allows the user the capability of sharing a single port interface device connected to the "COMMON" port among four other devices connected to the "A", "B", "C", and "D" ports with remote access functionality. Remote Control access can be accomplished using an Ethernet 10/100Base-T connection and either Telnet commands or Graphical User Interface. The Model 7426 is enclosed in a 1U, full rack size, all metal black chassis designed to provide EMI/RFI shielding and fit in a standard 19" rack.

FEATURES

- Allows quick connection to any one of four RJ45 devices from one COMMON device.
- The switch ports are transparent to all data.
- Pins 1, 2, 3, and 6 of the RJ45 interface are switched via break-before-make electromechanical relays.
- Eliminates the need to plug and unplug cables.
- Switch maintains position on power loss and continues to pass data.
- Front panel pushbutton control.
- Control of the switch position from a 10/100Base-T LAN Ethernet environment. IP Addressable!
- Remote Control Telnet Command interface or Graphical User Interface that allow the user to control switch position, lockout front panel operations, obtain switch status, and query firmware version number.
- Front panel LED's display present position and power status.
- **Certified for Cat5 (2 pair) compliance.**
- Attractive all metal black box packaging provides EMI/RFI shielding.
- Custom length RJ45 cables available for your switch installation.



SPECIFICATIONS:

PORT CONNECTORS: (5) RJ45 female connectors labeled A, B, C, D, and COMMON.

FRONT PANEL CONTROL: (4) Manual pushbuttons allow local switching.

DISPLAY: (4) Front panel LED's display switch position and power status.

REMOTE: (1) RJ45 female connector on rear panel accepts 10/100 Base-T LAN Access Ethernet and Graphical User Interface (GUI) for Remote control operation.

POWER: UL approved 100VAC-240VAC, 50Hz-60Hz wall mount power module supplies 12 VDC, 500 mA to the unit. Has 2-prong, US, non-polarized plug.

DIMENSIONS: Rackmount configuration 19.0" W x 1.75" H x 8.24" D. (48.3 x 4.4 x 21.0 cm)

WEIGHT: Approximately 4.3 lbs. (2.0 kg)

WIDE RANGE POWER OPTION AVAILABLE:

(Cat No 517277) **CE, RoHS, and UL** listed table mount power module, 100VAC-240VAC, 50Hz-60Hz for use in place of standard power module that is included with the unit. Has IEC 60320 C14 inlet. **Ideal for international applications.**

Model 7426 Application: Switching "ANY" RJ45 Cat5 (2 Pair) interface

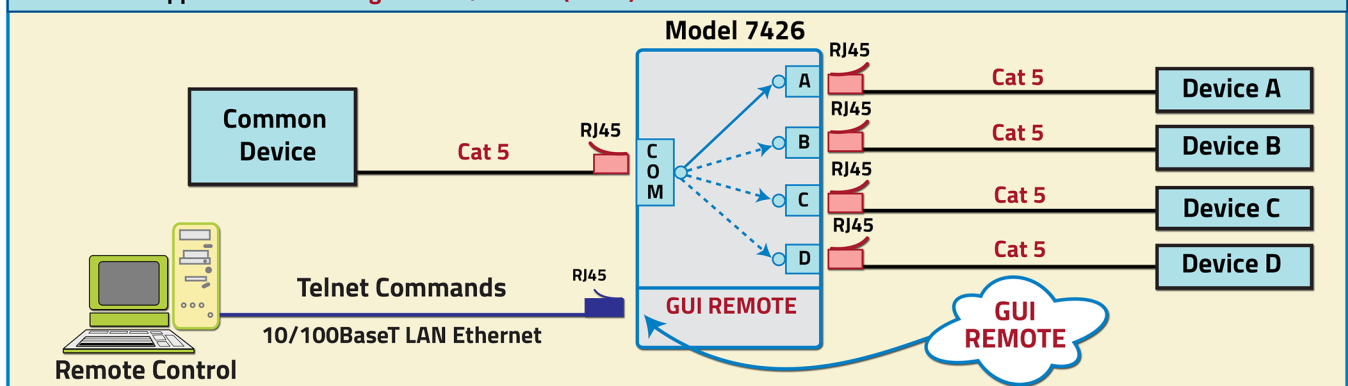

UTILIZING THE USER-FRIENDLY REMOTE GRAPHICAL USER INTERFACE SOFTWARE

To connect to the switch from a workstation or computer having access to the LAN that the Model 7426 LAN port is connected to, simply launch a standard web browser and type in the appropriate IP address. The Java Applet will be automatically uploaded from the switch upon connection. The environment requirement for the GUI is Java 1.7 and above.

SOFTWARE FEATURES

★ Graphical User Interface

- **Select a position:**
 - Select Position A, B, C, or D.
- **Lock and unlock** front panel pushbutton control.
- **Query** switch status.
- **Query** firmware version number.
- **GUI** is alerted to changes made by front panel pushbutton.
- Access User Interface via standard web browser.
- **Easy to use, simple point and click operation.**
- Remotely access to control or monitor the Model 7426 Switch System.
- Users can change the switch's IP address.
- LAN access gives users across the LAN or over the Internet access to control if user network is configured accordingly.

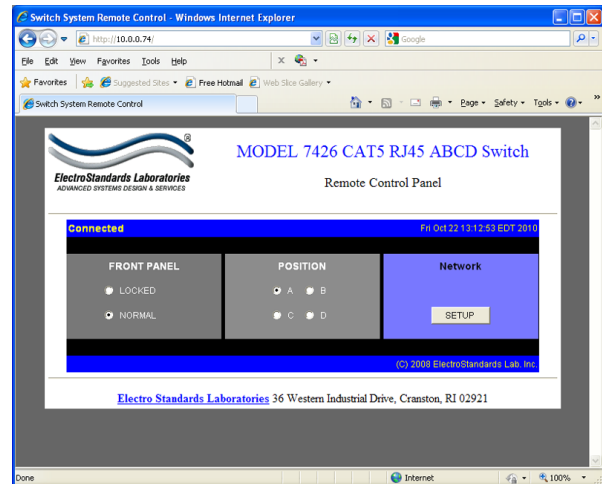
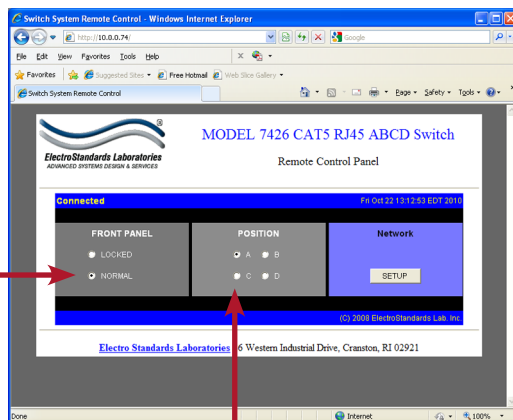

Figure 1: GUI in a Standard Web Browser

CHANGING POSITION AND LOCK STATUS

To change the switch position, click on the radio button "A", "B", "C", or "D" as desired. Locking and unlocking the front panel pushbutton can be done by clicking on the "Locked" or "Unlocked" radio buttons. See Figure 2.



Lock and unlock the front panel operation

Switch position by selecting "A", "B", "C", or "D".

Figure 2: Change the switch position or lockout front panel pushbuttons from the GUI

QUERYING THE STATUS OF THE UNIT

Once connected, the GUI will stay up-to-date on the current position and status of the unit. Any changes that are made outside of the GUI, such as by pushbutton, will be reflected in the GUI. These changes will cause the radio buttons of the GUI to automatically change to show the new status. See Figure 3.

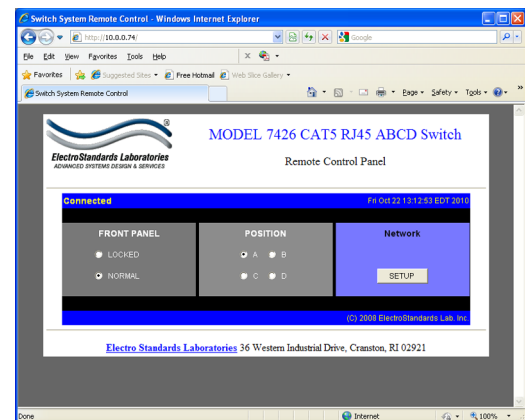

Figure 3: The GUI is alerted to changes in the unit status.