



**Electro Standards Laboratories**  
ADVANCED SYSTEMS DESIGN & SERVICES



**SPECIFICATIONS**  
**MODEL 7375**  
(Cat. No. 307375)

## PathWay® Model 7375 Cat5e RJ45 A/B/C Switch, Dual Remote Ports w/ Telnet and GUI

- **Extensive user manual covers Remote Ethernet Connection 10/100Base-T LAN Setup, Remote Telnet Session, and Remote Control GUI Operation**

### INTRODUCTION

The PathWay® Model 7375 Cat5e RJ45 A/B/C Switch with Telnet and GUI and Dual Remote Ports allows the user the capability of sharing a single port interface device connected to the "COMMON" port among three other devices connected to the "A", "B", and "C" ports.

Remote Control access can be accomplished using an Ethernet 10/100Base-T connection via Remote 1 and Remote 2. The graphical user interface allows for Remote switch position control and monitoring as well as front panel lockout features. The Model 7375 is enclosed in a 1U, full rack size, all metal, black chassis designed to provide EMI/RFI shielding and fit in a standard 19" rack.

### FEATURES:

- Allows quick connection of any one of three devices from one COMMON device.
- The switch ports are transparent to all data.
- All (8) pins of the RJ45 interface are switched via break-before-make electromechanical relays.
- Switch maintains position on power loss and continues to pass data.
- Front panel pushbutton control.
- **Dual Remote Control Ports.**
- Control of the switch position from two 10/100Base-T LAN Ethernet environments. IP Addressable!
- Remote Control Telnet command interface or Graphical User Interface that allows the user to control switch position, lockout front panel operations, and obtain switch status.
- Remote control of the switch is password protected, where the password protection can be disabled.
- Front panel LED's display present position and power status.
- Certified for Cat5e compliance.
- Attractive all metal, black box packaging provides EMI/RFI shielding.
- Custom length Cat5e RJ45 cables available for your switch installation.



### SPECIFICATIONS:

#### PORT CONNECTORS:

(4) RJ45 Cat5e female connectors labeled A, B, C and COMMON.

**FRONT PANEL CONTROL:** (3) manual pushbuttons allow local switching.

**DISPLAY:** (3) Front panel LED's display switch position and power status.

**DUAL REMOTE CONTROL:** (2) RJ45 female connectors on rear panel accept 10/100Base-T access Ethernet for remote control operation labeled Remote 1 and Remote 2.

**POWER:** UL approved 100VAC-240VAC, 50Hz-60Hz wall mount power module supplies 12VDC, 500mA to the unit. Has 2-prong, US, non-polarized plug.

**DIMENSIONS:** Rackmount:  
19.0" W x 1.75" H x 8.21" D. (48.3 x 4.4 x 20.9 cm)

**WEIGHT:** Approximately 4.4 lbs (2.0 kg)

### WIDE RANGE POWER OPTION AVAILABLE:

(Cat No 517277) **CE, RoHS, and UL** listed table mount power module, 100VAC-240VAC, 50Hz-60Hz for use in place of standard power module that is included with the unit. Has IEC 60320 C14 inlet. **Ideal for international applications.**

### PathWay® Model 7375 A/B/C Switch Application with Dual Remote Ports & Telnet and GUI:

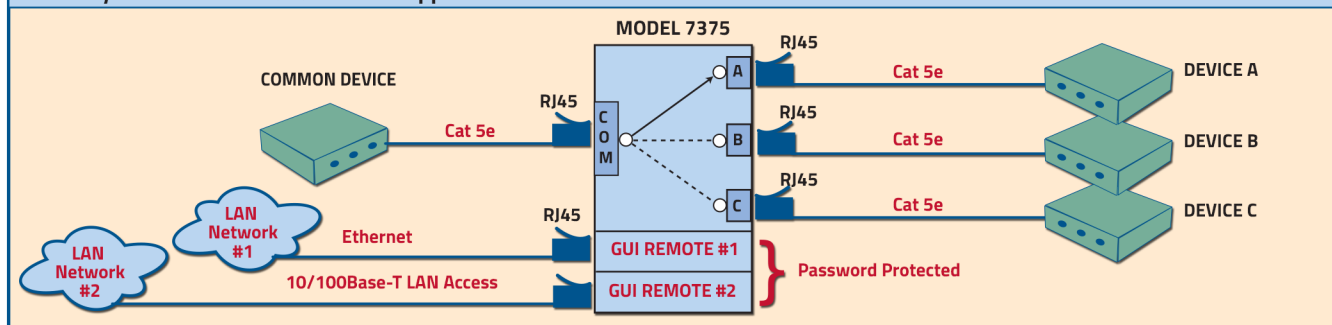

## UTILIZING THE USER-FRIENDLY REMOTE GRAPHICAL USER INTERFACE SOFTWARE

To connect to the switch from a workstation or computer having access to the LAN that the Model 7375 LAN port is connected to, simply launch a standard web browser and type in the appropriate IP address. The Java Applet will be automatically uploaded from the switch upon connection. The environment requirement for the GUI is Java 1.7 and above.

### 10/100BASE-T LAN SETUP

#### Network Setup

The switch is configured from the factory to use DHCP to automatically get its IP address from a DHCP server on the local area network when connected to the network and powered up. Therefore, a DHCP server is needed on the local area network for the initial configuration. After that, the switch can be configured to use a static IP address. To find the IP address of a switch that it has gotten from the DHCP server, or to reconfigure the IP Address of the switch, use the Lantronix® DeviceInstaller application.

#### Getting DeviceInstaller

DeviceInstaller requires Microsoft's .NET Framework version 4.0 or higher. If the .NET Framework is not already installed, it must first be installed. The .NET Framework can be downloaded from Microsoft's website, either as a web install, or as a standalone installation. The latest version of DeviceInstaller can be downloaded from Lantronix's website.

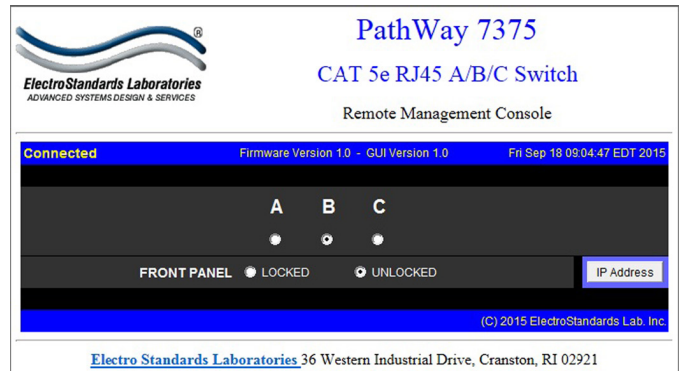

Figure 1: GUI in a Standard Web Browser

### SOFTWARE FEATURES

- Access User Interface via standard web browser.
- **Easy to use, simple point and click operation.**
- Remotely access to control or monitor the Model 7375 Switch System.
- Users can change the switch's IP address.
- LAN access gives users across the LAN or over the Internet access to control if user network is configured accordingly.

### CHANGING POSITION AND LOCK STATUS

To change the switch position, click on the radio button "A", "B", or "C" as desired. Locking and unlocking the front panel pushbutton can be done by clicking on the "Locked" or "Unlocked" radio buttons. See Figure 2.

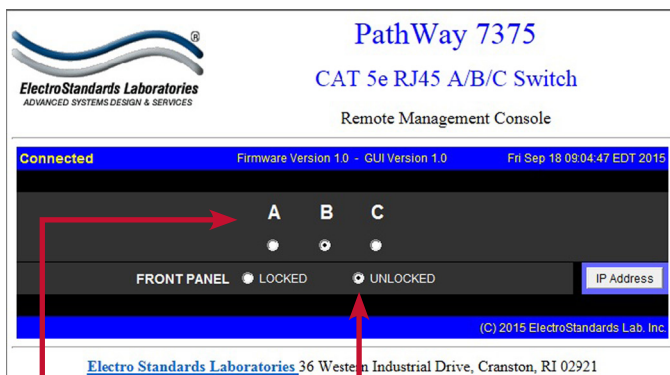

Switch position by selecting "A", "B",

Lock and unlock the front panel operation

Figure 2: Change the position and lockout from the GUI

### QUERYING THE STATUS OF THE UNIT

Once connected, the GUI will stay up-to-date on the current position and status of the unit. Any changes that are made outside of the GUI, such as by pushbutton, will be reflected in the GUI. These changes will cause the radio buttons of the GUI to automatically change to show the new status. See Figure 3.

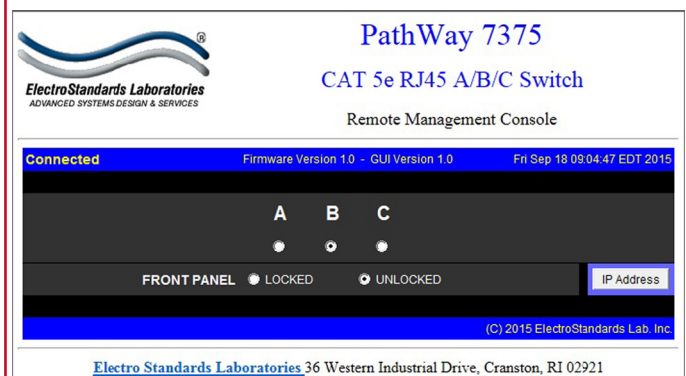

Figure 3: The GUI is alerted to changes in the unit status.