

PathWay® Model 7320 8-Channel RJ45 CAT6 A/B/C/D Switch with Telnet, GUI, and Cascade Operation

- **Applicable to ANY RJ45 transfer Switch Requirement!**

INTRODUCTION

The PathWay® Model 7320 8-Channel RJ45 Cat6 A/B/C/D Switch with Telnet, GUI, and Cascade Operation allows the user the capability of sharing a single port RJ45 interface device, connected to the "COMMON" port, among four other devices, connected to the "A", "B", "C", and "D" ports, for each channel. The Model 7320 is enclosed in a 2U, full rack size, all metal black chassis designed to provide EMI/RFI shielding and fit in a standard 19" rack.

The unit can be operated by either the front panel pushbuttons or the 10/100Base-T LAN Ethernet Remote. The unit also supports cascade operation, where other supported units can be connected and operated through a single remote port interface. The state of the unit can be obtained from the front panel LED's or through the Remote Telnet Commands or Graphical User Interface.

FEATURES:

- **Supports (8) channels of A/B/C/D switch function.**
 - The switch ports are transparent to all data.
 - All (8) pins of the RJ45 interface are switched via break-before-make electromechanical relays.
 - Switch maintains last set position on power loss and continues to pass data.
 - Individual control of each channel.
 - Front panel pushbutton control.
 - Remote Control of the switch from a 10/100-Base-T LAN Ethernet environment.
 - Remote Control Telnet Command Interface or Graphical User Interface that allows the user to control switch position, lockout front panel operations, control cascaded units, as well as obtain switch status and receive cascade unit status updates.
 - Cascade operation allows control of switch position and lockout as well as obtaining status of another unit connected to the cascade ports through the remote Telnet Interface or Graphical User Interface of a single unit.
 - Cascade operation is compatible with the Model 7321 (Catalog #307321), and other Model 7320 units.
 - Front panel LED's display present position and power status.
- **Cat6 compliance.**
- For a 12-Channel unit, See Model 7321, Cat No 307321.



SPECIFICATIONS:

PORT CONNECTORS: (40) RJ45 female connectors. (5) labeled A, B, C, D and COM for each of eight channels.

REMOTE CONTROL: (1) RJ45 female connector on rear panel accepts Ethernet 10/100Base-T connection and either TELNET commands or Graphical User Interface for Remote operation.

CASCADE PORTS: (1) RJ45 female connector labeled IN, and (1) RJ45 female connector labeled OUT.

LED's: (32) indicate present position and power status. (4) LED's for each of eight channels

CONTROL: (8) Pushbuttons; (1) for each of eight channels allows local control.

POWER: UL approved 100VAC-240VAC, 50Hz-60Hz wall mount power module supplies 12 VDC, 500mA to the unit. Has 2-prong, US, non-polarized plug.

DIMENSIONS: 19.0" W x 1.75" H x 10.0" D. (48.3 x 4.5 x 25.4 cm)

WEIGHT: Approximately 8.1 lbs. (3.7 kg)

WIDE RANGE POWER OPTION AVAILABLE:

(Cat No 517277) **CE, and UL** listed table mount power module, 100VAC-240VAC, 50Hz-60Hz for use in place of standard power module that is included with the unit. Has IEC 60320 C14 inlet. **Ideal for international applications.**

PathWay® Model 7320 8-Channel RJ45 CAT6 A/B/C/D Switch with Telnet, GUI, and Cascade Operation

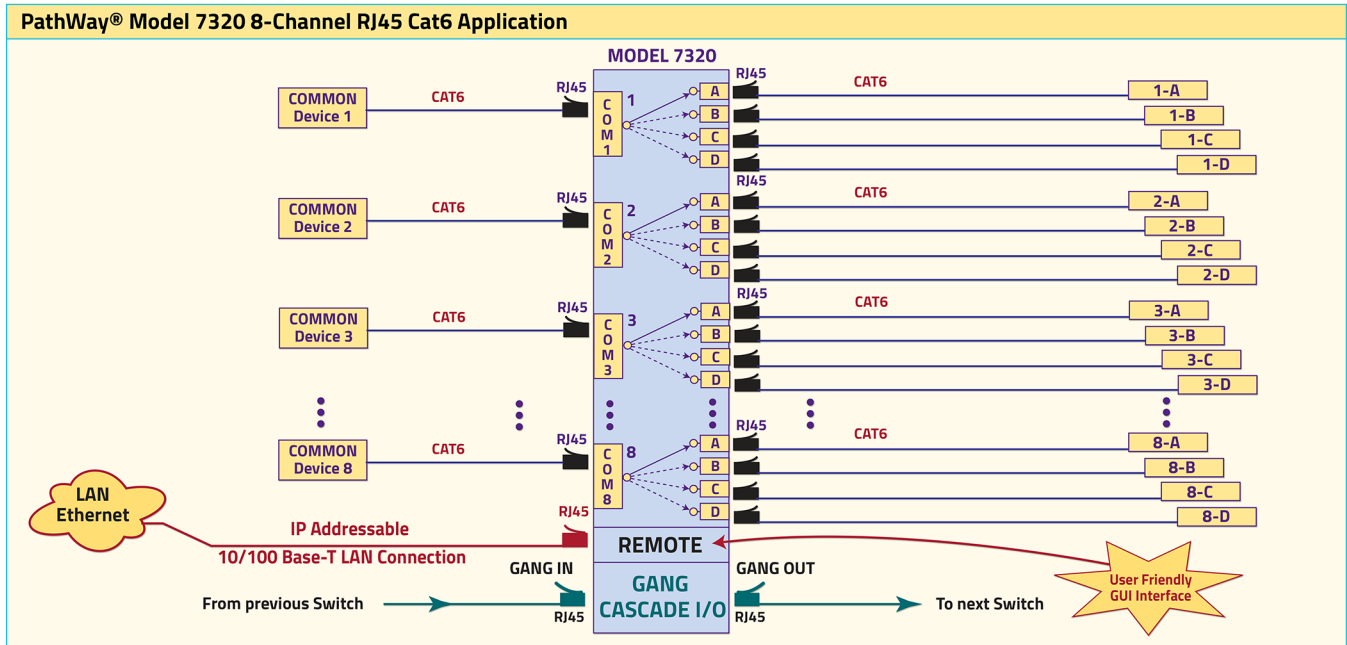

Ethernet Remote Port, I.P. Addressable, with GUI

UTILIZING THE USER FRIENDLY REMOTE GRAPHICAL USER INTERFACE SOFTWARE

To connect to the switch from a workstation or computer having access to the LAN that the switch's LAN port is connected to, simply launch a standard web browser and type in the appropriate IP address. The Java Applet will be automatically uploaded from the switch upon connection. The environment requirement for the GUI is Java 1.7 and above.

CHANGING SWITCH POSITION AND LOCK STATUS

To change the position of a channel, click on the radio button "A", "B", "C", or "D" as desired. Locking and unlocking the front panel pushbuttons can be done by clicking on the "Locked" or "Unlocked" radio buttons. Note: Since the GUI also supports access for the Model 7321, which is a 12-channel unit, Model 7320 units will show a space for Channels 9-12 that is blocked off.

Switch position by selecting "A", "B", "C" or "D"

Lock and unlock the front panel operation

Channels 9-12 only when Model 7321 12-channel unit is selected from the Model 7320 8-Channel GUI.

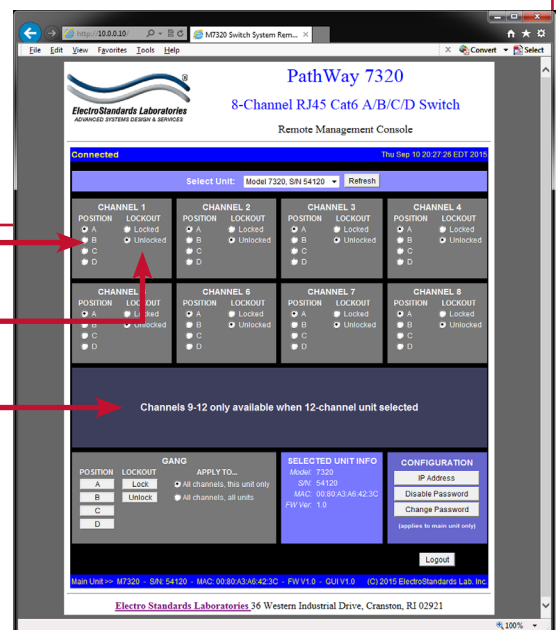

Figure 1: Change the position and lockout from the GUI