

PathWay® Model 7199 4-Channel BNC A/B Switch with RS485 Remote

- **Great for Audio, Video Remote Switch Applications!**

INTRODUCTION

The PathWay® Model 7199 4-Channel BNC A/B Switch with RS485 Remote allows the user the capability of sharing a single BNC interface device connected to the Common port among two other devices connected to the "A" and "B" ports, for each channel. The Model 7199 is enclosed in a 1U, full rack size, all metal black chassis designed to provide EMI/RFI shielding and fit in a standard 19" rack.

There is no "local" or front panel switch controls on the unit. The Model 7199 can ONLY be switched remotely from the DB9 RS485 Serial Interface Remote port located on the rear of the unit. The front panel LED display indicates the position of the unit.

FEATURES:

- Each channel allows access to two BNC networks from one COMMON BNC network or device.
- Four independent switch channels may be switched individually or simultaneously.
- The switch ports are transparent to all data.
- Only the center pin of the BNC interface is switched via break before-make electromechanical relays. The shells of the BNC interface are tied together and separated by channel.
- The unit maintains last set position on power loss and continues to pass data.
- **No front panel pushbutton control.**
- **Remote port designed for RS485 multi-drop applications.**
- Remote RS485 ASCII commands that allow the user to control switch position and obtain switch status.
- Front panel LED's display present position and power status.
- Attractive all metal black box packaging provides EMI/RFI shielding.



SPECIFICATIONS:

PORT CONNECTORS: (3) BNC (F) connectors labeled A, B and COMMON for each Channel.

DISPLAY: (8) Front panel LED's display switch position and power status.

REMOTE: (1) DB9 female connector on rear panel accepts RS485 ASCII commands for Remote Control Operation.

POWER: UL approved 100VAC-240VAC, 50Hz-60Hz wall mount power module supplies 12 VDC, 500mA to the unit. Has 2-prong, US, non-polarized plug.

DIMENSIONS: Rackmount 19.0" W x 1.75" H x 10.75" D. (48.3 x 4.4 x 27.4 cm), (1U rack height).

WEIGHT: Approximately 5.6 lbs. (2.6 kg)

WIDE RANGE POWER OPTION AVAILABLE:

(Cat No 517277) **CE, RoHS, and UL** listed table mount power module, 100VAC-240VAC, 50Hz-60Hz for use in place of standard power module that is included with the unit. Has IEC 60320 C14 inlet. **Ideal for international applications.**

PathWay® Model 7199 4-Channel BNC A/B Application with RS485 Remote

- **No Front Panel Control**
- **Remote Port designed: For RS485 multi-drop applications!**

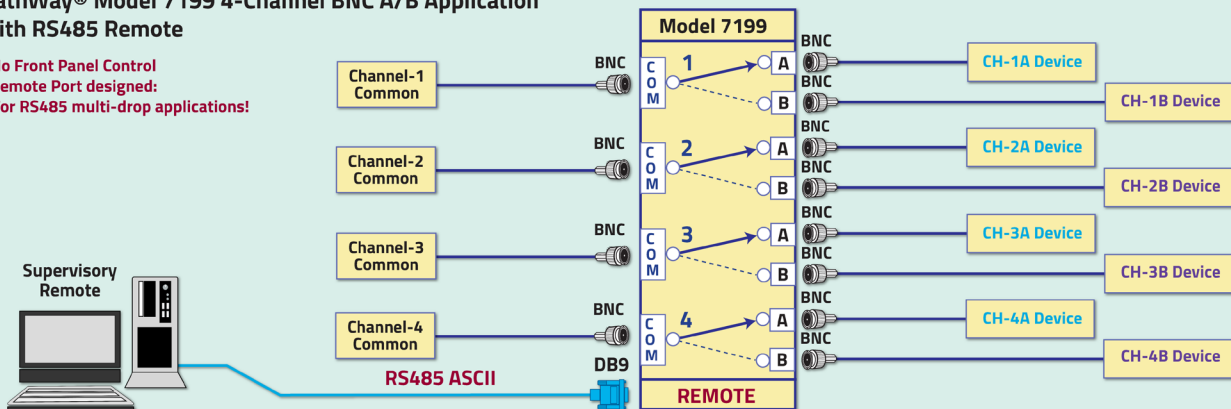

Suggested cables for use with Model 7199 Switch.

Part Number	Description	Unit Price
990136-006	RG58 Coaxial Cable, 50 ohm, 6 ft. (M/M)	Call for Price!
990136-010	RG58 Coaxial, 50 ohm, 10 ft. (M/M)	Call for Price!
890426-006	Thinnet RG58 Coaxial Cable, 50 ohm, 6 ft. (M/M)	Call for Price!
890426-010	Thinnet RG58 Coaxial Cable, 50 ohm, 10 ft. (M/M)	Call for Price!