

PathWay® Model 4875 Remotely Controllable Special Interface KVM A/B Switch

• Applicable to custom RS422 Keyboard

INTRODUCTION

The Model 4875 Remotely Controllable KVM A/B Switch allows the user the capability to access either of two computers from a single set of KVM devices. The keyboard, monitor, and mouse devices are connected to the Common set of ports, and the computers are connected to the A and B set of ports. The switch position can be controlled manually from the front panel pushbutton, or remotely by a simple contact closure connected to the RJ45 Remote port.

Remote Switching can be achieved by connecting to either of the optional remote units: Model 4856 Single Channel Console Remote or the 16-Channel Area Remote unit. Remote switching can also be achieved by connecting to your contact closure device.



Model 4875 FEATURES:

- PS/2 mouse port emulation
- Video port signals are regenerated
- Video resolution up to 1920 x 1440
- Video bandwidth 200MHz
- Custom RS422 keyboard port
- Mouse, Monitor, & keyboard all switched simultaneously
- Supports hot plugging the mouse port
- Switch by front panel pushbutton or remotely by contact closure
- Desktop enclosure

Remote port connection details:

If the Model 4875 detects a transition from open to closure and remains closed across pins 2 & 3, the unit will switch to the "B" position. If the Model 4875 detects a transition from closed to open and remains open across pins 2 & 3, the unit will switch to the "A" position.

SPECIFICATIONS:

- **REAR PANEL CONNECTORS:**
- **KEYBOARD PORTS:** (3) DB25/F connectors, keyboard ports A/B/COMMON, supports pins 2, 3, 4, 5, 6, 7, 8, 20
- **VGA MONITOR:** (3) HD 15/F connectors, VGA monitor ports, A/B/COMMON, full VGA interface supported
- **PS/2 MOUSE PORTS:** (3) Mini Din-6/F connectors, PS/2 mouse ports, A/B/COMMON, full PS/2 interface supported
- (1) Modular RJ45 connector, Remote port
- (1) Power jack
- **Power Supply:** autoranging external power module, 90 - 265 VAC, 50/60Hz, 10 Watts
- **Front Panel Controls:** (1) pushbutton
- **Indicators:** (2) red LED status indicators
- **Size:** 2.82" H x 7.94" D x 7.25" W (7.2 x 20.2 x 18.4 cm)
- **Weight:** 2 lbs. (0.9 Kg)
- **MTBF:** 100,000 hrs.
- **Operating Temperature:** 5 - 45 degrees C
- **Humidity:** 10% - 90%
- **Altitude:** 0 - 7000 ft above sea level

PathWay® Model 4875 KVM Switch Application:

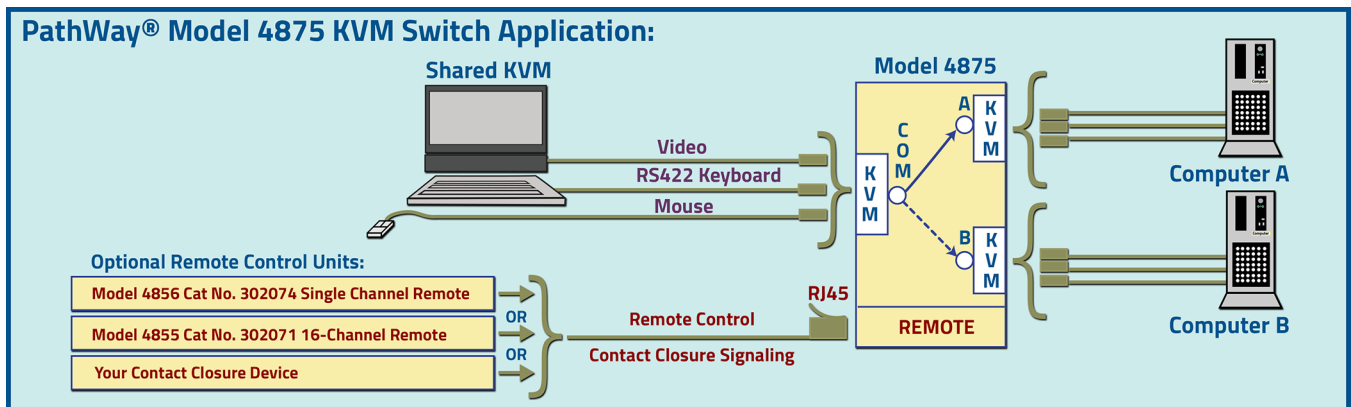

Application: PathWay® Model 4855 16-Channel Area Remote

- Provides remote switching of up to sixteen Model 4875 Remotely Controllable KVM A/B Switches

INTRODUCTION:

The Model 4855 is designed to provide remote switching and remote monitoring of up to sixteen Model 4875 Remotely Controllable KVM A/B Switches. A front panel two-position rotary switch provides the contact close transition or contact open transition signals required by the KVM switches for remote control operation. A/B status of all KVM switches connected to the Model 4855 (can be as many as sixteen) are displayed via the front panel LED's.

Model 4855 FEATURES:

- Remotely controls switching of up to 16 Model 4875 KVM A/B Switches.
- High intensity red LED indicators display status of up to 16 remotely located Model 4875 KVM A/B Switches.
- Front panel rotary switch allows simultaneous A/B control of all KVM switches connected to its ports.
- Easy connection to KVM units being controlled via 16 RJ45 ports on rear panel.
- Attractive, yet rugged, aluminum enclosure.
- Dimensions: 2.5" H. x 7.5" D x 13.5" W. (6.4 x 18.8 x 34.3 cm)
- Weight: 2.5 lbs. (1.1 kg)

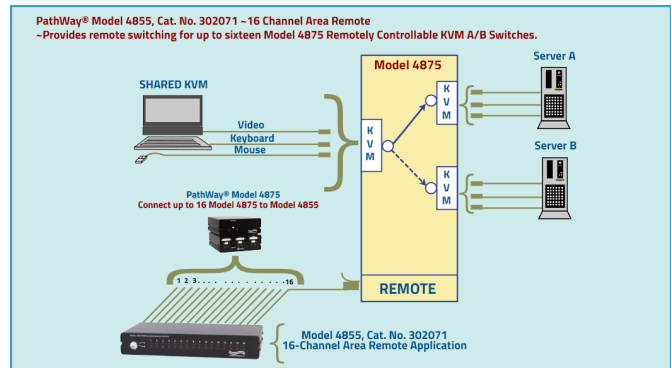

Application: Model 4856 Single Channel Remote

- Provides remote switching for one Model 4875 Remotely Controllable KVM A/B Switch

Introduction:

The Model 4856 Single Channel Remote Unit for switches with contact closure control. This unit displays current position of the switch it is controlling remotely by illuminating red LED indicators.

Model 4856 FEATURES:

- High intensity red LED indicators display status of switch being controlled.
- Provides reliable Contact Closure required to remotely control the KVM switch.
- Captive cable plugs directly into the RJ45 Remote port of the Model 4875 KVM Switch.
- Small metal enclosure 0.8" x 1.3" x 2.0". (2.0 x 3.3 x 5.0 cm)

