

Model 4404 Eight Channel Remote Power Reboot Switch with 10 Base-T LAN/WAN Access

- **Remote Reboot Power Switch, Rackmount, 8-Outlets.**
- **Total AC Power Control to Eight Devices Via Internet, IP Switched.**

Can Reboot Eight Remote Devices...

The Power Reboot Switch with 10 Base-T LAN/WAN Remote Access permits the user to cycle power to eight remotely located devices that may become locked up.

Easy to Use...

The Model 4404 Power Reboot Switch can be strategically located near equipment prone to lock up problems. Those units plug into the Model 4404 AC power outlets. The connected devices can be remotely restarted by the user by accessing the Model 4404 via a 10 Base-T connection.

By simply entering in the IP address of the Power Reboot Switch into a standard Web browser, a graphical representation of the Power Reboot Switch is accessed. The user chooses any of eight AC outlets individually, or in groups, and removes and restores power, allowing the selected peripheral to re-initiate and resume normal operation.

Controls, Connections, Indicators, and Such...

The front panel controls include a System Reset pushbutton to set the unit to factory default. Indicator LED's display the power, switch position, and LAN presence for remote control. There are eight power outlets on the rear panel grouped into two circuits of four. Each circuit is supported by a single 120 VAC input with a maximum current rating of 15 Amps. Each outlet within the circuit can switch up to the rated 15 Amps.

FEATURES:

- Access User Interface via standard Web browser.
- No special software required.
- Login username and password authentication required.
- Easy to use, simple point and click operation.
- Remote access to control or monitor the eight power outlets of the Model 4404 Power Remote Switch.
- User privilege level configuration creates users with different authorities.
- **IP Addressable! LAN access gives users across the LAN or over the Internet access to control power switch.**
- Rackmount Dimensions: 19" W x 3.5" H x 10.0" D. (48.3 x 8.9 x 25.4 cm)
- Weight: Approximately 5.0 lbs. (2.3 Kg)



Model 4404

SPECIFICATIONS:

POWER: (2) 120 VAC, 60 (Hz) Inputs).

DISPLAY: (4) Port status LED's and (2) Line Power LED's.

CONNECTIONS: (8) 120 VAC outlets.

USER CHANNELS: Eight power channels.

REMOTE: (1) RJ45 connector on rear panel accepts 10 Base-T Ethernet interface LAN/WAN access for Remote control operation.

DIMENSIONS: Rackmount Configuration, 19.0" W x 3.5" H x 10.0" D. (48.3 x 8.9 x 25.4 cm)

WEIGHT: Approximately 5.0 lbs. (2.3 Kg)

IP Addressable!

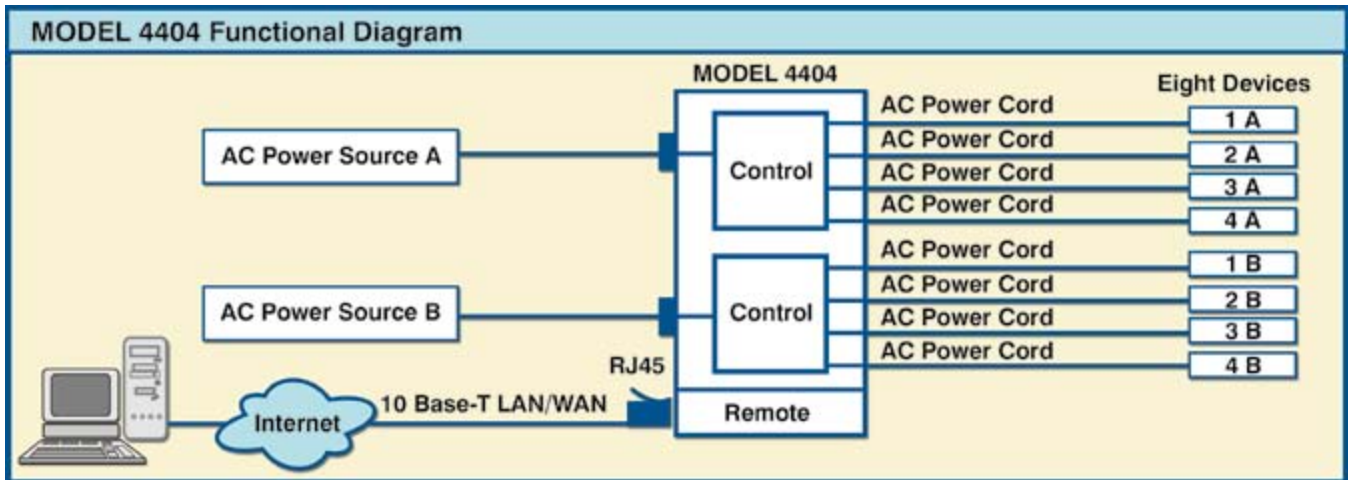

Remote Control:

The Model 4404 Power Reboot Switch can be remotely accessed via its 10-Base-T LAN/WAN Remote port. To connect to the Model 4404 from a workstation / computer, all that is required is a standard web browser. Depending on assigned user privileges, users can be assigned rights to access individual ports, groups of ports, setup users, configure ports/units, and configure the LAN access parameters.

