



Electro Standards Laboratories
ADVANCED SYSTEMS DESIGN & SERVICES

SPECIFICATIONS

SENSOR BOARD: Model 1100 (Cat No. 519286)
OPTIONAL: Mating Connector Kit (Cat No. 517258)

Three Channel Current Sensor Board (100 Amp x 3)

- Provides safe, non-intrusive, reliable current sensing for Power Electronics applications.
- Precise current sensing with fast response time.

INTRODUCTION:

The Model 1100 is a three channel closed loop (compensated) current sensor unit which uses the Hall effect. The board contains three independent **100 amp** current sensors, which can either be independently powered or bussed together by means of jumper settings. Sensor full scale can be scaled by applying wire turns through the sensor body. For detailed connector Pin-outs and signal information, request Free User Manual.

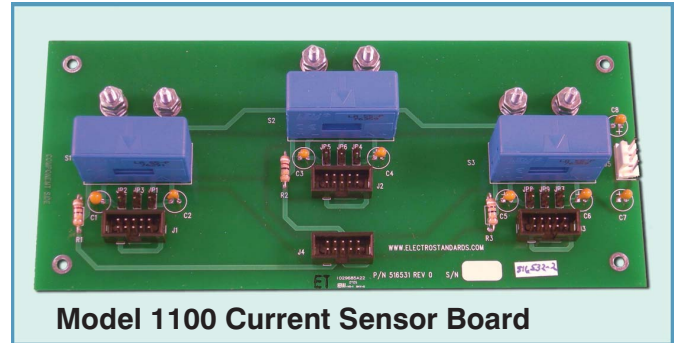

SPECIFICATIONS:

General Data:

Primary Nominal RMS current **100A**
Primary Current Measurement Range 0, +/-150A
Supply Voltage (+/-5%) +/-12V, +/-15V

Measuring resistance @ 12 V – 91 Ohms
Secondary nominal RMS current 50mA
Conversion Ratio 1:2000

Accuracy (@ +/-15V) +/-0.45%
(@ +/-12V) +/-0.70%

Reaction Time @10% of IPN – <500ns
Response Time @90% of IPN – <1µs
Frequency Bandwidth (-1 dB) – DC, 200 kHz
Ambient operating temperature -41 to +85°C

Mechanical (Board Only):

Model / Cat No: 1100 / 519286
Size: 8.0" x 3.5" x 1.27" (20.3 x 8.9 x 3.2 cm)
Weight: 4.6 oz (130.41g)
Mounting: Four 0.15" Mounting Holes

**For 50-Amp Version, See:
Model 1050, Cat. No. 516532.**

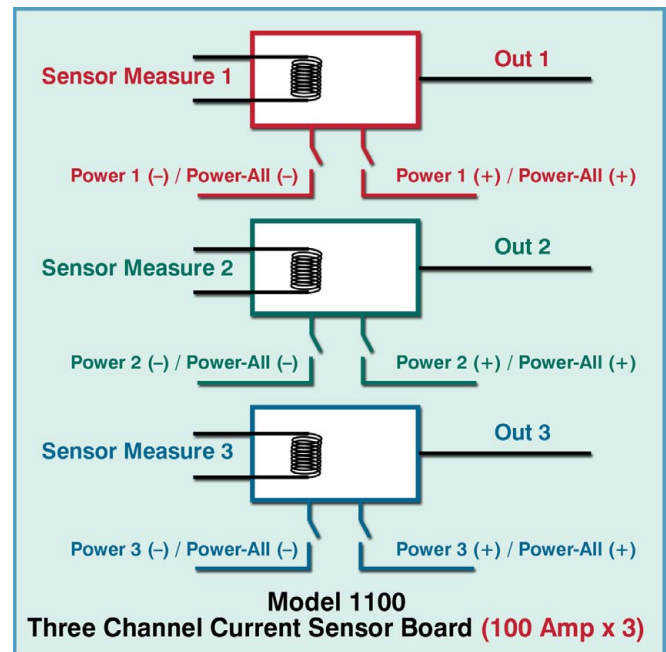

OPTIONAL: Connector Kit Cat No 517258



OPTIONAL: Mating Connector Kit includes:

- (4) 10-Position (5 x 2) IDC connector with strain relief.
- (1) 20C, 28 AWG rainbow ribbon cable, 4 foot length.
- (1) 3-Position 0.156" spacing, female connector housing.
- (3) Female crimp contacts for 0.156" connector (for 12-18 AWG wire).
- (9) 0.1" spacing, shunt clips.
- **To Order Use Cat No 517258**