

SCUPS® Model 1027 SuperCapacitor 12VDC Uninterruptible Power Supply, Desktop Configuration

- Provides critical power backup for remote locations.
- Recognized for significant advantages over battery UPS systems.
- Low Maintenance, Long Service Life, Wide Temperature Range

The **SCUPS®** Model 1027 SuperCapacitor based Uninterruptible Power Supply is designed to provide nominal 12VDC power when a unit's 12VDC line power is interrupted. In addition, several digital signals are available to alert the host system that supplemental power is in use, and to provide a state of charge (SOC) indication. User applications can use digital signals to commence an orderly shutdown operation and can use the SOC signals to gauge the level of energy in the super capacitor. Once Primary power is restored, the unit's super capacitor is recharged and becomes ready for the next power interruption event. **The use of the SuperCapacitor for energy storage provides a very low maintenance solution with extremely high cycle life and without the shelf life concerns of typical battery backup systems.** The **SCUPS®** is perfect for low power remote systems where primary power can be interrupted. Typical applications include remote locations with intermittent grid power or renewable energy systems such as solar powered systems. The **SCUPS®** Model 1027 is also available as a board unit that can easily be integrated into user equipment (See Model 1026, Catalog Number 301026).



SPECIFICATIONS:

Max Power to Load:

12W, 12 VDC at 1A

Max Primary Load Voltage:

15 VDC

Voltage during Hold Up:

11.6 VDC

Hold Up Time:

14 minutes with 1A Load
29 minutes with 0.5A Load

Full Recharge Time:

103 minutes from full discharge to full charge

Min. Recharge Time:

37 minutes from full discharge (nominal times at 22°C)

Energy Storage:

Lithium Ion SuperCapacitor

Status Signals:

Digital: 2-State of Charge, Primary-ON, Backup-ON

Connectors:

Primary Power In: 2-Pin(M) Phoenix Connector
Protected Power Out: 2-Pin(F) Phoenix Connector
Status: DB9 (M) Connector

Temperature:

-25°C to 65°C

Dimensions:

7.760" x 5.550" x 1.550" (includes super capacitor)

Weight:

1.8 lb (includes SuperCapacitor)

Operation Manual Describes:

Power Connector, Activating the UPS, Deactivating the UPS, UPS System Operations, Adjusting UPS Output Voltage Level, Hardware Specifications, Performance Specifications, UPS Discharge Characteristics, UPS Charge Characteristics, UPS Circuit Board Description, Digital Signal Pin Out, Digital Output Component Specifications.

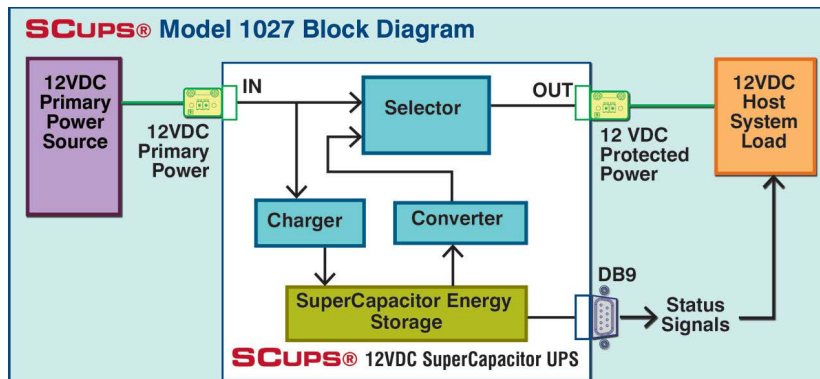

ALSO AVAILABLE AS A BOARD UNIT

SCUPS® Model 1026

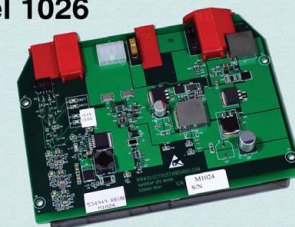

(Board Unit)...Model 1026
(Cat No. 301026)